



Thaco Trailers



**THACO INDUSTRIES TRAILERS AND HEAVY STEEL
STRUCTURES MANUFACTURING LIMITED LIABILITY COMPANY**



(+84) 933 805 707



thacosv@thaco.com.vn



www.linkedin.com/in/thacotrailers

THACO Chu Lai Industrial Park, Nui Thanh District, Quang Nam Province, Vietnam



www.thacotrailers.com

CONTENTS

OVERVIEW

PRODUCTS

TECHNOLOGY

Design & Simulation

Fabrication

Welding

Painting

Assembly

Inspection

Packing







QUALIFIED SUPPLIERS

CUSTOMERS

EXPORT MARKETS





	Founded	2016
	Area	2.5 ha
	Capital	USD 25 million
	Capacity	30,000 units/year
	Workforce	500 people
	Products	Semi-trailers and Semi-trailers components

THACO INDUSTRIES TRAILERS AND HEAVY STEEL STRUCTURES MANUFACTURING LIMITED LIABILITY COMPANY was established in 2016. In 2023, the company invested and innovated to meet the capacity of 30,000 products per year.

The products are manufactured through modern processes with many advanced technologies and equipment, such as Fiber laser cutting machines, CNC pressing machines, automatic welding robots, semi-trailer chain turning equipment, shot blasting, ED dipping, powder coating,... The product meets the standard of the quality management systems (ISO 9001: 2015) and environment management systems (ISO 14001: 2015).

Until now, the company has provided products to customers in Vietnam and exported products to many markets such as the USA, Canada, Mexico, Australia, Japan, Korea, Thailand, Myanmar,...

PRODUCTS

NORTH AMERICAN MARKET



20'/40' City Combo Tandem



20'/40' Combo Tandem



20'/40' Combo Tridem



40'/45' Extendable Tandem



20' Slider Tandem



33' Slider Tandem



40' Gooseneck Tandem



40' Gooseneck Lightweight Tandem

PRODUCTS

NORTH AMERICAN MARKET



40' Gooseneck Tridem



53' Gooseneck Tandem



40'/53' Extendable Tridem



20'/40'/45' Combo Tridem



20'/40'/45' City Combo Tridem Without Genset



20'/40'/45' City Combo Tridem With Genset



20' Slider Tandem With Rear Fifth Wheel



Dolly Tandem

PRODUCTS

STRATEGIC DEVELOPMENT PRODUCTS

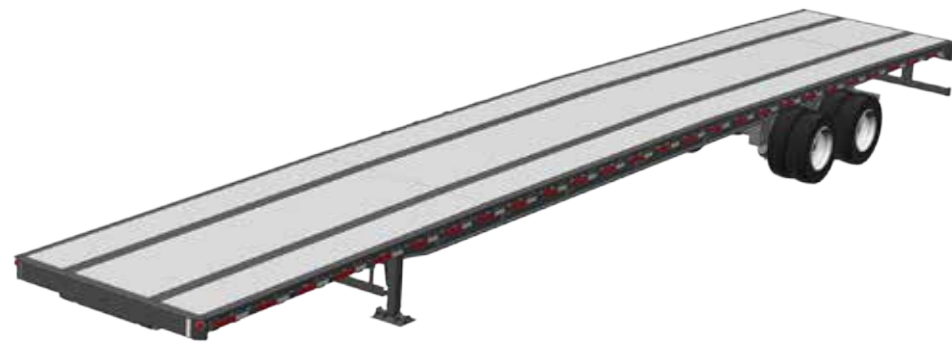

Flatbed



Tiny House Carrier



Drop Deck



Low Bed



Water Tanker



B-Double



Dry Van



Dolly

PRODUCTS
OTHER MARKETS



20' Skeleton Tandem, 4 Twist Locks



40' Skeleton Tridem, 8 Twist Locks



45' Gooseneck Tridem, 6 Twist Locks



48' Gooseneck Tridem, 6 Twist Locks



40' Flatbed Tridem, 8 Twist Locks



45' Flatbed Tridem, 10 Twist Locks



Heavy dump, 23m³



Car Carrier

LIST OF COMPONENTS



Landing gear



Main Frame



Wire harness



Leaf Spring



Slider Frame



Suspension



Plastic ring, Hose Clamps



Wheel



Tire



Air Tank



Document holder



Mud flaps



TOTAL AREA 16,100M²
INCLUDING 4 MAIN
PRODUCTION LINES

01 WELDING LINE

02 PAINTING LINE

03 ASSEMBLY LINE

04 INSPECTION LINE

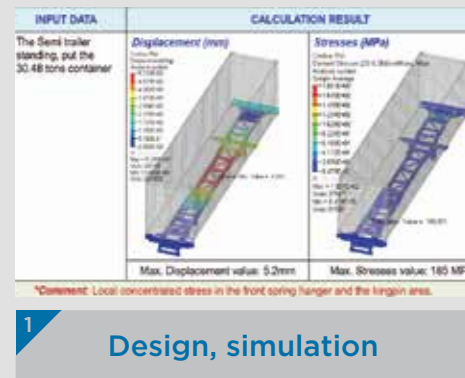

1 Design, simulation



2 Input material



3 Fabrication



4 Welding



8 Packing



7 Inspection



6 Assembly



5 ED, painting, shot blasting

DESIGN & SIMULATION



- DESIGN PROCEDURE
- DESIGN CONTROL DRAWING
- 2D, 3D SIMULATION

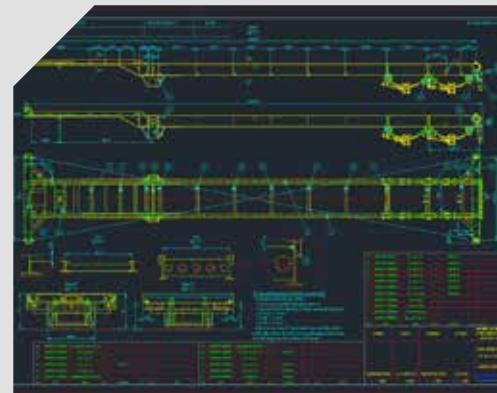

2D DESIGNING AUTOCAD SOFTWARE

Description, overview and detail calculation of products.
Dimension and tolerance display.

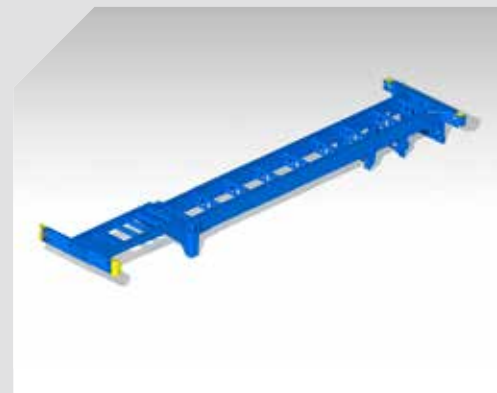

3D DESIGNING, NX SOFTWARE

The optimization for durability calculation and accuracy increasing.
Assembly processing display.

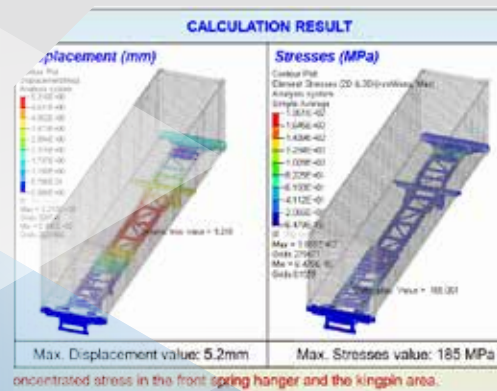

SIMULATION, CALCULATION: HYPERWORKS

Simulation, analyzing, data management
Product structural strength calculation.
Design and production processing optimization.



Testing machine
(material properties testing)



Surface roughness
testing machine



Ultrasonic welding
testing machine



Spectrograph machine
(material composition testing)

FABRICATION



- ▶ WORKPIECE CUTTING:
CNC laser cutting machine,
CNC Plasma, CNC Oxy Gas...
- ▶ PREVENTING VARIATION OF
WELDING CONNECTING POINTS:
Hydraulic Press Machine, Lathe,
Milling,...



SLITTING LINE

Thickness: 0.3 - 6 mm
Width material: 50 - 1,200 mm



FIBER LASER CUTTING MACHINE

Power: 15,000 W
Cutting size: 6,200 - 2,500 mm



CNC PRESSING MACHINE

Thickness material: 0.6 - 12 mm
Max-length: 12,000 mm



3D FIBER LASER
CUTTING MACHINE

Cutting size: □20 - 220 mm; Ø20 - 220 mm
Thickness: 10 mm (steel); 5 mm (stainless steel)



I BEAM LASER CUTTING MACHINE

Power: 6,000 W
Max cutting thickness: 21 mm
Max workpiece dimension: I 400x200x13,300 mm

WELDING



▶ CAPACITY:
55 chassis/day
Dump box, semi-trailer welding



AUTOMATIC WELDING EQUIPMENT

Manufacturer: Miller (American)
Working length: 40,000 mm



SEMI TRAILER
CHAIN TURNING EQUIPMENT

Max load: 10 tons
Dimension (LxWxH): 6,000 x 4,100 x 5,000 mm



1 BD & WD cross beam



3 Front bolster and rear bolster welding



2 Small parts welding



4 Chassis welding robot



5 Upside turning

PAINTING



▶ CAPACITY:
55 chassis/day



SHOT BLASTING BOOTH

Max material: 15,000 x 8,925 x 11,078 mm
Load: 5,000 kg



AUTOMATIC POWDER COATING ROBOT

Max material: 20,900 x 9,200 x 7,140 mm
Load: 4,000 kg



ED COATING LINE

Max material dimension: 17,000 x 1,600 x 3,700 mm
Salt mist resistance: 1,000 hours



AUTOMATIC POWDER COATING GUN SYSTEM

Power: 70,000 W
Quantity: 30 guns

ASSEMBLY



1 Air system assembly



2 Electrical system assembly



3 Landing gear assembly



4 Suspension system & axle assembly



7 Air system connection and finalizing



6 Tighten wheel nuts



5 Tire assembly

INSPECTION



1 Brake system inspection



2 Under pit inspection



4 Road test



3 Weight inspection

PACKING



1 Stacking into bundle



2 Fastening



4 Handover



3 Inspection

QUALIFIED SUPPLIERS



CUSTOMERS



EXPORT MARKETS

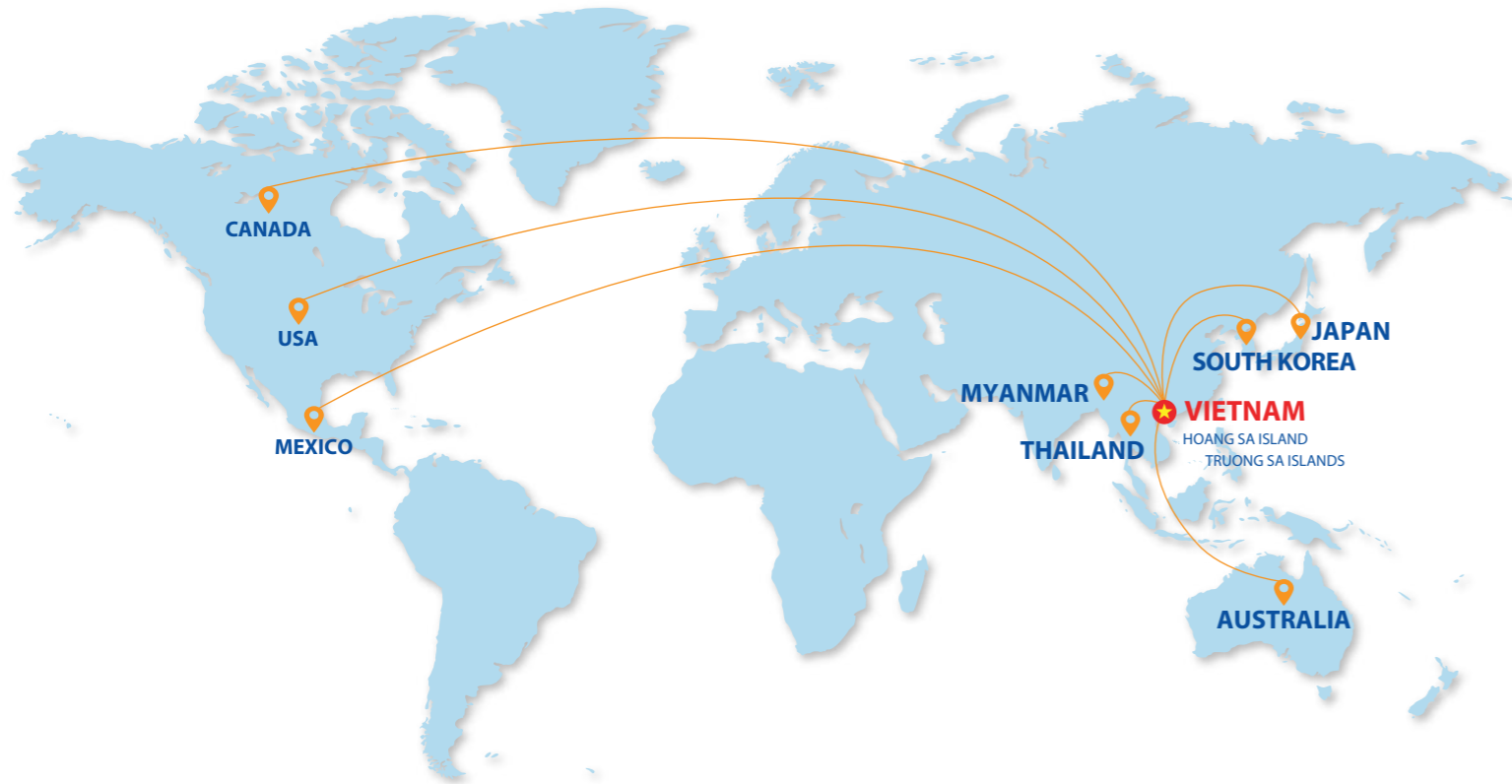

INTERNATIONAL DELIVERY

Thaco Trailers offers international multimodal transportation services with Incoterm delivery conditions such as EXW, FCA, FOB, CIF, and DDP. Particularly for the US market, we provide delivered duty paid (DDP term), ensuring maximum benefits for our customers.

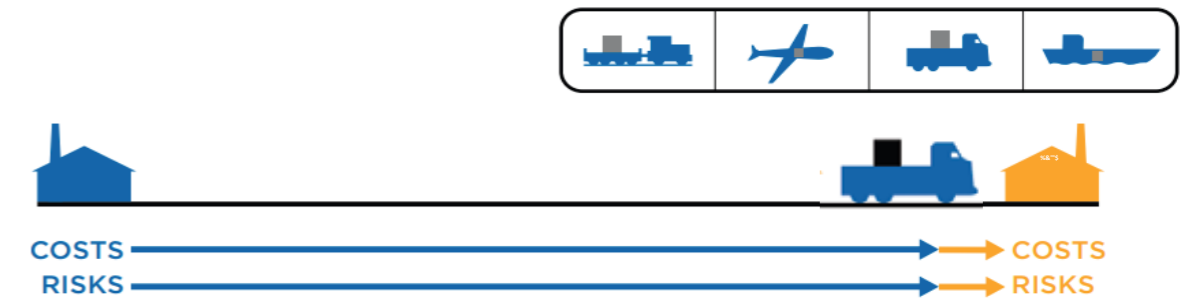

Risk Mitigation: As a registered Foreign Importer of Record (FIOR) with U.S. Customs and Border Protection (CBP), we will be the legal importer for the products and will handle all customs procedures, ensuring compliance with import market regulations and standards, minimizing risks, and optimizing benefits for our customers.

Transparent Costs: With a tightly controlled supply chain, we guarantee transparency in all information and shipping costs to customers.

Time savings: By entrusting Thaco Trailers, customers optimize customs and shipping procedures without relying on external import agents, saving valuable time.

OUTSTANDING EVENTS

