



ThacoTrailers

SKELETAL SEMI-TRAILER 40' TANDEM, 8 TWIST LOCKS



TECHNICAL SPECIFICATION		
Dimension	mm	12,280 x 2,480 x 1,530
Wheelbase	mm	8,540 + 1,310
Tare weight	kg	4,355
Authorized pay load	kg	30,000
Total mass	kg	34,355
Main beam	mm	Welded beam 482/140
Axle	FUWA 13 tons	
Kingpin	2" (ø50), bolted connection	
Landing gear	FUWA 28 tons	
Twist Locks	8	
Suspension System	Spring hanger	Mechanical Suspension – FUWA
	Leaf spring	4 leaf springs (90x20 mm)
Control Valve	Wabco	
Brake System	Locked on 2 axles	
Electrical System	10 – 30V (suitable for all tractor types)	
Tire size	11R22.5	
Painting technology	Shot blasting SA 2.5 ED coating Topcoat	
Paint color (upon request)	Blue (standard color)	

The product is covered by a 36-month warranty (details outlined in the accompanying warranty booklet) and can be serviced at any authorized THACO AUTO dealership nationwide.

**THACO INDUSTRIES TRAILERS AND HEAVY STEEL STRUCTURES
MANUFACTURING LIMITED LIABILITY COMPANY**

📍 THACO Chu Lai IP, Nui Thanh District, Quang Nam Province, Vietnam
☎ 0938 901 260 ✉ thacosv@thaco.com.vn



www.thacotrailers.com

DURABLE - SAFE - ECONOMICAL

Thaco Trailers continuously invests in advanced technologies to create superior and reliable products.



CHASSIS

Modern design, advanced manufacturing technology, high-strength alloy steel material, solid structure, increased load capacity with high stability.

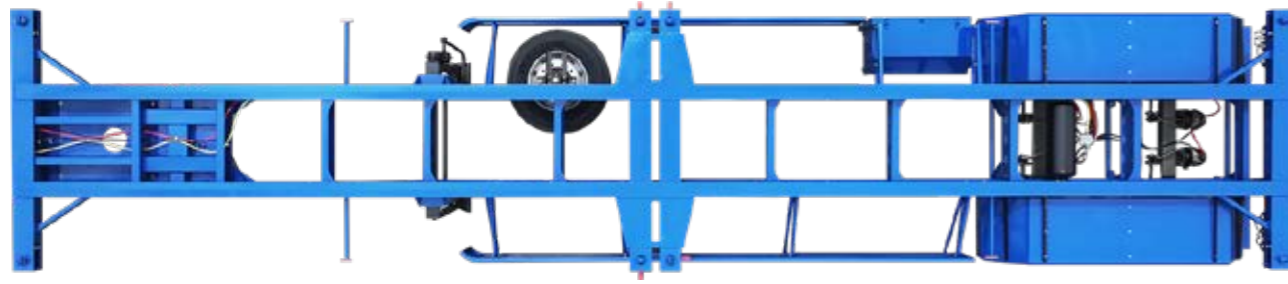

AXLE

FUWA 13-ton axle.



TIRES

Uses 11R22.5 tires.



SUSPENSION SYSTEM

The suspension system uses 4 leaf springs system with high durability and large load capacity, ensuring smooth operation



BRAKE SYSTEM

2-axle air brake system with WABCO splitter valve to help prevent tire slippage when braking, ensuring safe operation

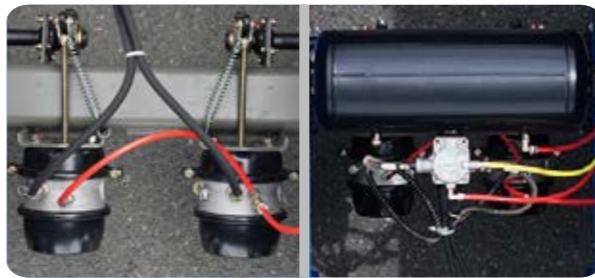

ELECTRICAL SYSTEM

High-quality LED lighting system capable of withstanding harsh weather conditions, using 10-30V power source compatible with all types of tractors.



LANDING GEAR

FUWA landing gear with a dynamic load capacity of 28 tons and a static load capacity of 80 tons, helps to effectively distribute weight, preventing excessive pressure on each structure of the semi-trailer.



DIMENSIONS

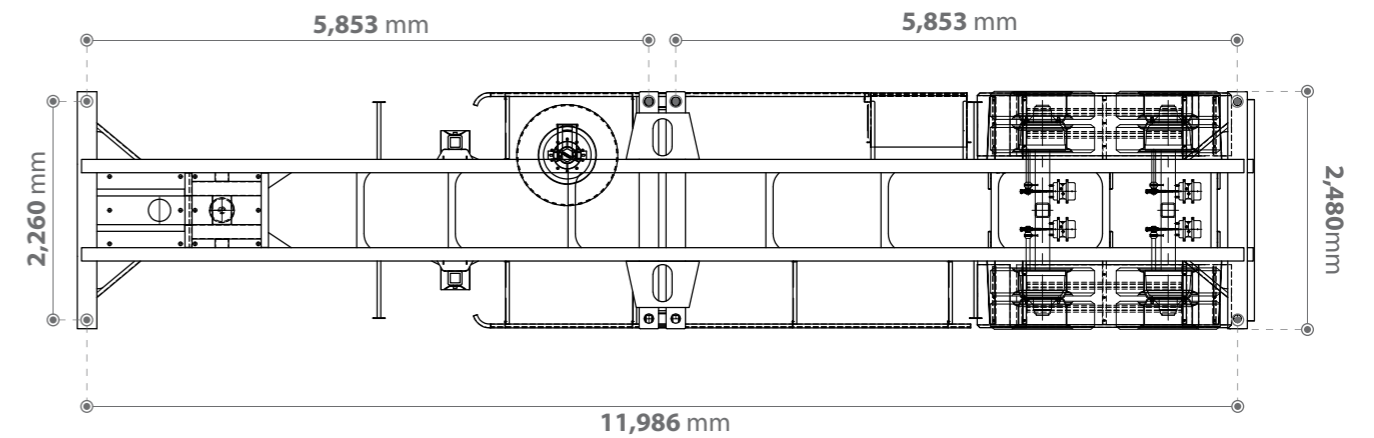
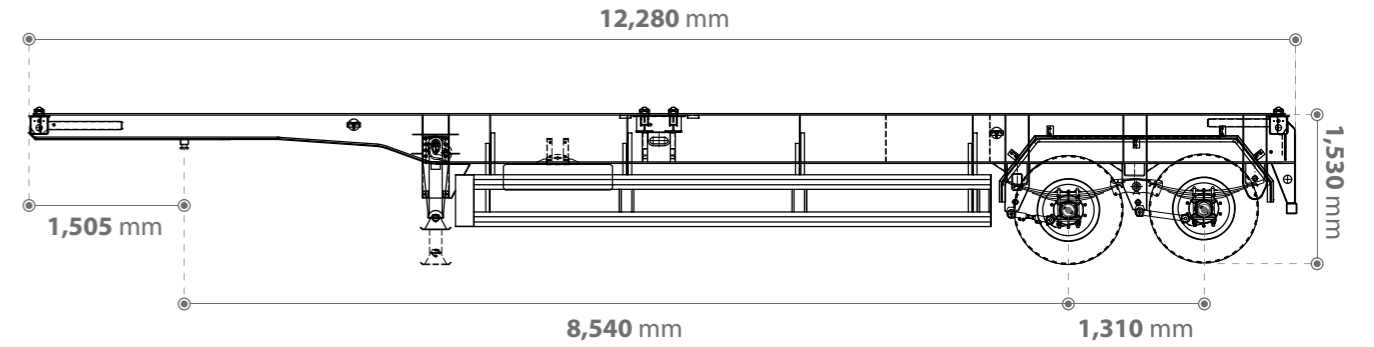

CARGO CAPACITY

