



Thaco Trailers

SIDEWALL SEMI-TRAILER CARGO OR CONTAINER TRANSFER



TECHNICAL SPECIFICATION		
Overall dimension	mm	12,400 x 2,500 x 2,660
Wheelbase	mm	7,530 + 1,310 + 1,310
Tare weight	kg	7,120
Maximum design/authorized pay load	kg	32,880 / 31,825
Maximum design/authorized total mass	kg	40,000 / 38,945
Main beam dimension	mm	Welded beam 565/140
Axle	FUWA 13 tons	
Kingpin	2" (ø50), bolted connection	
Landing gear	FUWA 28 tons	
Twist locks	8	
Suspension system	Spring hanger	Mechanical Suspension – FUWA
	Leaf spring	7 leaf springs (90x16 mm)
Control valve	WABCO	
Brake system	Locked on 3 axles	
Electrical system	10 – 30V (suitable for all tractor types)	
Tire size	12R22.5	
Painting technology	Shot blasting SA 2.5 Primer Topcoat	
Paint color (upon request)	Blue (standard color)	

The product is covered by a 36-month warranty (details outlined in the accompanying warranty booklet) and can be serviced at any authorized THACO AUTO dealership nationwide.

THACO INDUSTRIES TRAILERS AND HEAVY STEEL STRUCTURES
MANUFACTURING LIMITED LIABILITY COMPANY

📍 THACO Chu Lai IP, Nui Thanh District, Quang Nam Province, Vietnam
☎ 0938 901 260 ✉ thacosv@thaco.com.vn



www.thacotrailers.com

DURABLE - SAFE - ECONOMICAL

Thaco Trailers continuously invests in advanced technologies to create superior and reliable products.

CHASSIS

Modern design, advanced manufacturing technology, high-strength alloy steel material, solid structure, increased load capacity with high stability.



AXLE

FUWA 13-ton axle.



SUSPENSION SYSTEM

The suspension system uses 7 leaf springs system with high durability and large load capacity, ensuring smooth operation.



ELECTRICAL SYSTEM

High-quality LED lighting system capable of withstanding harsh weather conditions, using 10-30V power source compatible with all types of tractors.



TIRES

Uses 12R22.5 tires.



BRAKE SYSTEM

3-axle air brake system with WABCO splitter valve to help prevent tire slippage when braking, ensuring safe operation.



LANDING GEAR

FUWA landing gear with a dynamic load capacity of 28 tons and a static load capacity of 80 tons, helps to effectively distribute weight, preventing excessive pressure on each structure of the semi-trailer.



DIMENSIONS

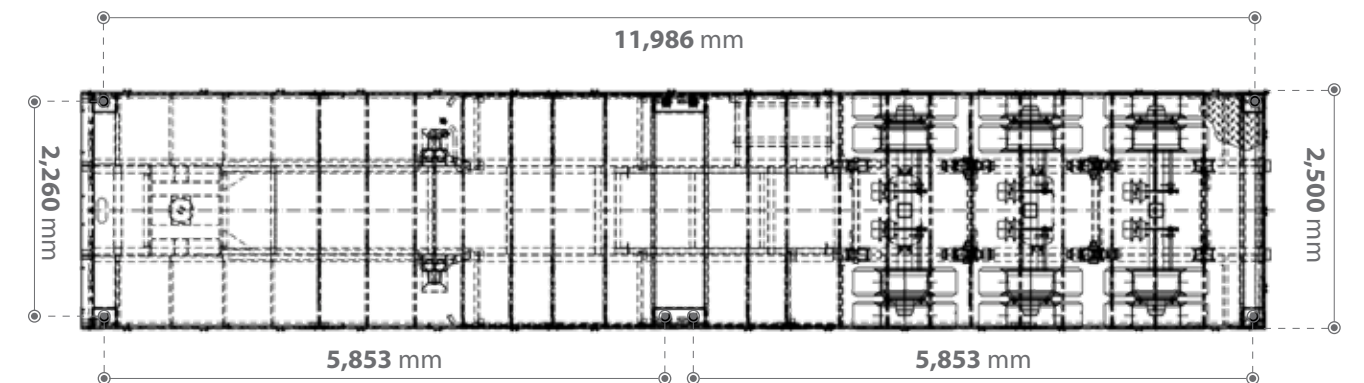
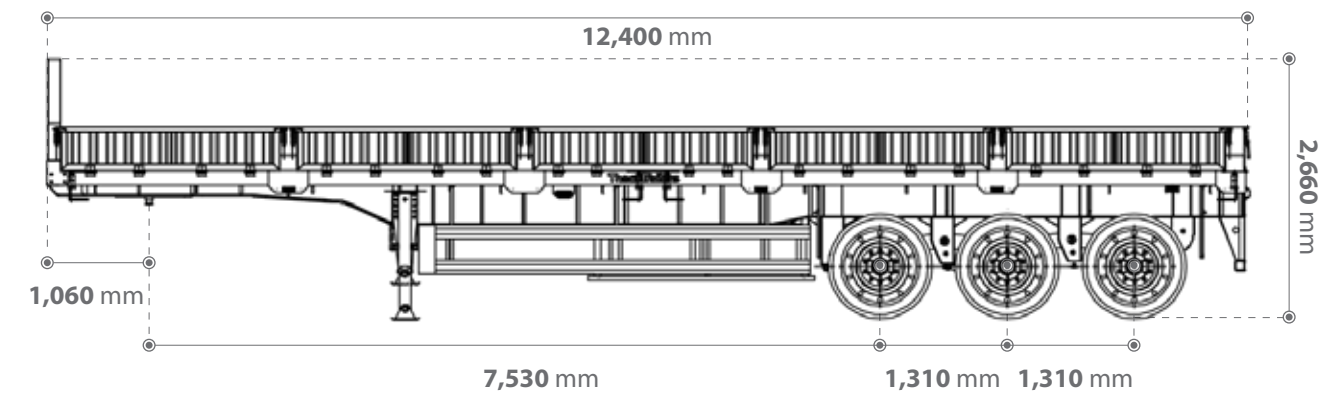

CARGO CAPACITY

