

GENERAL	
Overall Length	31' 7" (retracted) or 40' 11" (extended)
Overall Width	96"
Fifth Wheel Height	47 ± 1"
Rear Deck Height	48 ± 1"
Kingpin Location	18" (From rear face of front bolster)
Landing Gear Location	100" (From the centerline of kingpin)
Tandem location	32" (From rear face of rear bolster to rear axles center when extended)
Axle Spread	109"
Tare Weight	9,350 lbs ± 3%
Payload	54,500 lbs for 20' loaded or 57,000 lbs for 40' loaded
STEEL STRUCTURE & COMPONENTS	
Main beam	16"x5" fabricated I-beam with high strength flanges and 6-11/32" height for gooseneck rail. ASTM Grade 130
Upper Coupler	5/16" pick up plate with JOST (USA) 2" diameter square type kingpin per SAE standard, 380-420 HB, with 2" water drain holes, design to be integrated with main frame through welding
Front Bolster	Fabricated bolster assembly with high strength plates with 89" centers, equipped with none retractable twist locks. Local supplier (Vietnam)
Intermediate Bolster	Fabricated with retractable twistlocks with swing down twistlocks. Local supplier (Vietnam)
Rear Bolster	Tapered rectangle bolster of the main frame fabricated by 3/8" thick top and bottom plate with 5/16" thick side plates. 6-5/8" height x 4" wide fabricated box beam bolster on slider composed by 1/2" thick top/bottom plates with 5/16" thick side plates with flip up twistlocks. Local supplier (Vietnam)
Slider beam	Fabricated I beam with 3/4"x5" upper and lower flanges and 3/16" web, slider extends or retract on 6" diameter steel rollers. Local supplier (Vietnam)
Locking system	Air operated locking pins, activated by HALDEX (Mexico) Goldseal 30/30 spring brakes on both sides of the trailer through third gladhand on front sill
Landing Gear	SAF-HOLLAND (USA) ATLAS65 with 65,000 lbs capacity, 2-speed 17" travel with low "T" shoes Crank handle is located on the driver's side of the chassis. Pre-painted BLACK color Landing gear brackets are bolted on the main beam as the layout
Container locks	BUFFERS (India) & VAN DOORN (Turkey) / SCHULZ (Spain)
Suspension	HUTCH (USA) 109" axle spread, underslung configuration with STANDEN (Canada) high-arch single spring (360-00). Pre-painted BLACK color
Axles	YORK (India) 5" round axles with 22,500 lbs capacity; 71.5" track, Q+ 16.5"x7" 4515Q brake. Pre-painted BLACK color 1.5-28 spline, HALDEX (India) 5.5" automatic slack adjusters None reserved PSI interface; Heat Sensing Labels Axle Installation orientation: 90 degrees REAR, chambers DOWN (1 abs ready front, 1 non abs rear per unit)
Wheel end	YORK (India) Hub & Drum Assembly. STEMCO (USA) 358-4009 Integrated Sentinel Grease Hub Cap with umbrella valve. SKF (USA) seals P/N Scotseal plus XL 46300 ORBIT TN (India) bearings Spindle nut: YORK (India) Double Nut. (5-year warranty wheelend)
Lubricant	MOBILITH SHC 007 (India) Synthetic Semi-fluid grease lubricant
Wheels	SUNRISE (Vietnam) 22.5 x 8.25 10-stud hub-piloted wheels with 5 hand holes and with TR572 valve stem Pre-painted WHITE color
Tires	WESTLAKE (Thailand) 255/70R22.5-16PR tubeless type
Brake System	SEALCO (USA) 110800 spring brake priority valve system and WABCO (Thailand/ USA/ Germany/ Poland) 2S/1M ABS system. PHILLIPS (USA) glad hand 12-0061 and 12-0081. TECTRAN (USA) 3/8" blue air tube for control and 3/8" red for supply. HALDEX (Mexico) Goldseal T30/30, 2.5" stroke brake chamber. THACO CMC (Vietnam) air tank (Pre-painted BLACK color)
Electrical	PHILLIPS (Mexico) mold seal wiring harness, Reserved PSI and GPS connector. (10-year warranty) OPTRONICS (Taiwan) LED lights (amp connections for S/T/T lights and. 180 bullets for others) The theft proof design used for 4" LED lighting
Electrical Receptacle	PHILLIPS (Mexico) 16-724 plastic material with solid pins
Document Holder	THACO Plastic Components (Vietnam) . Installed on roadside near crank handle
Conspicuity tape	"3M" (Singapore) brand. Installed per federal regulations
Painting	Abrasive blast of all metal surfaces - not less than SA-2.5 to achieve clean bare steel. Surface will be coated with electrophoresis primer and powder topcoat. Color BLACK RAL9005 and at the corner painted YELLOW color. Total thickness not less than 80µm after dry membrane. Coating supplier: PPG (Vietnam) (7-year warranty)
Marking	Customer configuration (includes Decal, layout, VIN & nameplate). Local supplier (Vietnam)
Tire Inflation System	NONE
Hubdrometer	NONE
Mud flaps	THACO Plastic Components (Vietnam) 18"x24"x1/4" White PVC mud flaps with "CUSTOMER" logo



Thaco Trailers

20'/40' COMBO TANDEM



Retracted Length	Extended Length	Overall Width	Payload 20'	Payload 40'	Tare Weight
31' 7"	40' 11"	96"	54,500 lbs	57,000 lbs	9,350 lbs

Strong and efficient, this chassis is made for handling both ISO 20' and ISO 40' containers. Spread axles at 109 inches offer greater balance capability compared to standard spacing



**THACO INDUSTRIES TRAILERS AND HEAVY STEEL STRUCTURES
MANUFACTURING LIMITED LIABILITY COMPANY**

© THACO Chu Lai Industrial Park, Nui Thanh District, Quang Nam Province, Vietnam
© (+84) 933 805 707 📧 thacosv@thaco.com.vn

www.thacotrailers.com

BALANCE – STURDINESS – FLEXIBILITY

Thaco Trailers equipped cutting-edge technologies to create durable and reliable products



CHASSIS

Modern design with the most advanced technology, high-strength alloy steel materials, solid structure increase the load capacity with high stability.

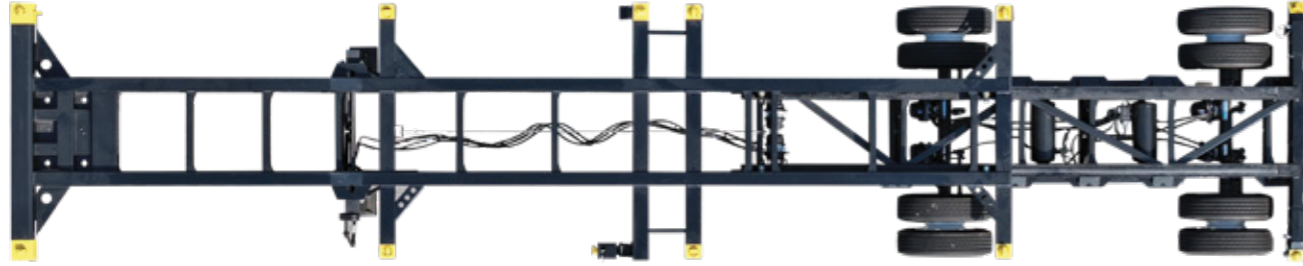

AXLES

YORK (India) 5" round axles with 22,500 lbs capacity increases load capacity and improves handling significantly.



SUSPENSION SYSTEM

HUTCH (USA) 109" axle spread, underslung configuration with **STANDEN (Canada)** high-arch single spring supports the spring assembly absorb greater loads, which increases load capacity.

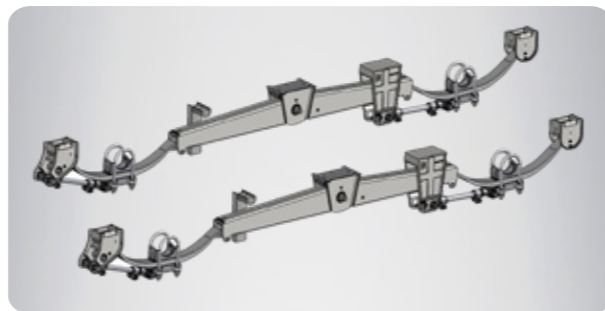

UPPER COUPLER

5/16" pick up plate with **JOST (USA)** 2" diameter square type king pin per SAE standard is a strong and reliable connection between the tractor and trailer.



LOCKING SYSTEM

Air operated locking pins, activated by **HALDEX (Mexico)** Goldseal 30/30 spring brakes, prevent the trailer from becoming disconnected from the tractor.



LANDING GEAR

SAF-HOLLAND (USA) ATLAS65 with 65,000 lbs capacity, makes trailer lift and lower operations easier when connecting a tractor.



PAINTING

Surface treatment and painting processes including shot blasting, ED primer and powder topcoat are standard technical requirements.

- Paint finishes are warranted for up to 7 years.
- 1,000 hours of salt spray testing.



WHEELS & TIRES

SUNRISE (Vietnam) 22.5 x 8.25 10-stud hub-piloted wheels are durable, precise, and safe wheels for heavy-duty trucks.

WESTLAKE (Thailand) 255/70R22.5-16PR tubeless type provides good traction on various terrains.



ELECTRICAL SYSTEM

PHILLIPS (Mexico) mold seal wiring harness, protects wires from environmental factors and damage.

OPTRONICS (Taiwan) LED lights are designed to be theft-resistant and withstand harsh conditions.



BRAKE SYSTEM

SEALCO (USA) 110800 spring brake priority valve system improves vehicle performance and safety.

WABCO (Thailand/USA/Germany/Poland) 2S/1M ABS system improves vehicle control and reduces the risk of accidents.



STANDARD INFORMATION

- This chassis meets all DOT, AAR, ANSI, TOFC, F(C)MVSS, SAE and TTMA certifications.
- Locally-sourced components: Main frame, suspension system, leaf spring,...

